

TTR200 / TTR200X RTD TEMPERATURE TRANSMITTER

- **MULTI TYPE RTD, SLIDE WIRE, RESISTANCE INPUTS**

- **ATEX, UKEX AND IEC Ex APPROVED VERSION**

- **SENSOR OFFSET or OUTPUT ALIGNMENT**

- **ADJUSTABLE INPUT FILTER**

- **PROGRAMABLE BURNOUT**

- **INTRODUCTION**

The TTR200 'smart' transmitter is designed for use with RTD or slidewire sensors. The flexible design allows the use of any resistive sensor within the range of (10 to 10500) Ω . Pt100, 500, 1000, Ni or Cu sensors as well as slide wire sensors up to 100 K Ω can be accommodated. Other sensor characteristics or your own 22-point linearization characteristic (for slidewire or linear resistance) can be downloaded into the product enabling you to adapt it exactly to your application. The TTR200X is approved to UKEX, ATEX and IEC Ex standards allowing for use in hazardous area applications.

PC configuration allows the user to select Sensor type, Range, Filter, Tag, Units and error signal without requiring calibration equipment. Additionally, the user may read live process data when connected to the PC, this allows for sensor offset, and output alignment calibration, where the user can enter values to match the actual process and therefore reducing system errors.

If required, the desired range can be specified at the time of order, removing the need for user configuration. If the range is not specified then the transmitter will be shipped with the default range of Pt100 (0 to 100) $^{\circ}\text{C}$, burnout high and filter off.

➤ **FEATURE HIGHLIGHTS**

SENSOR REFERENCING (Temperature mode)

The TTR200 sensor referencing via the Windows based USBSpeedlink software allows for close matching to a known reference sensor eliminating possible sensor errors.

CUSTOM LINEARISATION

As standard the TTR200 has all common RTD sensors available from its software library. Additionally, the TTR200 can be programmed with up to 22-point custom linearization for ohms and slidewire inputs.

SENSOR BURN OUT DETECTION (Temperature mode)

If a sensor wire is broken or becomes disconnected the TTR200 output will automatically go to its user defined level (upscale or downscale) or a pre-set value.

STABILITY

The TTR200 in head transmitter incorporates the latest digital technology to ensure accurate, low drift performance.

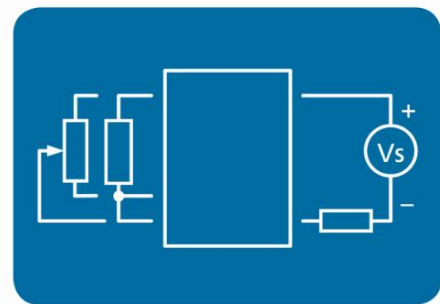

TTR200 / TTR200X RTD TEMPERATURE TRANSMITTER

ELECTRICAL INPUT		SPECIFICATIONS @20 °C
Type	Range	Accuracy/ Stability
Slide Wire		
(0 to 100) % Travel	Wire resistance (1 to 100) K Ω	$\pm 0.1 \%$
Resistance		
Ohms	(10 to 500) Ω (500 to 2500) Ω (2500 to 10500) Ω	$\pm 0.055 \Omega$ $\pm 0.5 \Omega$ $\pm 10.0 \Omega$
Thermal drift	(10 to 500) Ω (500 to 2500) Ω (2500 to 10500) Ω	$\Omega 0.013 \Omega/^\circ\text{C}$ $\Omega 0.063 \Omega/^\circ\text{C}$ $\Omega 0.27 \Omega/^\circ\text{C}$
Excitation current		< 200 μA

SENSOR INPUT RTD		SPECIFICATIONS @20 °C
Type	Range	Accuracy/ Stability
Pt100 (IEC)	(-200 to 850) $^\circ\text{C}$	$\pm 0.2^\circ\text{C} \pm (0.05\% \text{ of reading})$ (Plus sensor error)
Pt500 (IEC)	(-200 to 850) $^\circ\text{C}$	
Pt1000 (IEC)	(-200 to 600) $^\circ\text{C}$	
Ni100	(-60 to 180) $^\circ\text{C}$	
Ni120	(-70 to 180) $^\circ\text{C}$	
Ni1000	(-40 to 150) $^\circ\text{C}$	
Cu53	(-40 to 180) $^\circ\text{C}$	
Cu100	(-80 to 260) $^\circ\text{C}$	
Cu1000	(-80 to 260) $^\circ\text{C}$	
Lead effect	Max lead resistance 20 Ω per leg	0.002 $^\circ\text{C} / \Omega$
Library contains more (standards/types) Including silicon sensors		
Temperature stability: - Refer to resistance stability values for thermal effect		

OUTPUT		SPECIFICATIONS @20 °C
Type/ Function	Range/ Description	Accuracy/ Stability/ Notes
Two wire current	(4 to 20) mA	(mA output /2000) or 5 μA (Whichever is the greater)
Thermal drift	Zero at 20 $^\circ\text{C}$	2 $\mu\text{A} / ^\circ\text{C}$
Maximum output current	21.5 mA	In high burnout condition
Minimum output current	< 3.9 mA	In low burnout condition
Loop voltage effect	0.2 $\mu\text{A} / \text{V}$	
Maximum output load	$[(\text{V supply} - 10)/20]$ K Ω	700 Ω @ 24 V DC
Loop supply	(10 to 30) V DC	SELV
Power	< 1 W full power	

USB USER INTERFACE		
Type/ Function	Range/ Description	Notes
Configuration hardware	For TTR200	USB-CONFIG-MKII
	For TTR200X	USB-CONFIG-MKII USB-TTX-CONFIG
Configuration software	USBSpeedLink	Download www.status.co.uk
Temperature mode configuration	Sensor type	RTD list
	Temperature range for (4 to 20) mA retransmission	$^\circ\text{C}$ or $^\circ\text{F}$
	Sensor offset	$^\circ\text{C}$ or $^\circ\text{F}$
	Burnout current	Upscale, downscale or user set

TTR200 / TTR200X RTD TEMPERATURE TRANSMITTER

Type/ Function	Range/ Description	Notes
Process mode configuration	Input type	Ohms or slide wire
	Process range for (4 to 20) mA retransmission	User engineering units, 4 characters
	User linearisation	(2 to 22) segments
Tag number		20 characters
Filter	(0 to 100) s time constant	Adjustable
Read live data	Temperature / process output	°C or °F or user units for process mA
Save/ open configuration	From file	

GENERAL	
Function	Description
Update time	160 ms
Response time	0.5 s
Start-up time	5 s
Warm up time	120 s to full accuracy
Default configuration	PT100 (0 to 100) °C, upscale burnout

ENVIRONMENTAL	
Function	Description
Ambient temperature	Operating/Storage (-40 to 85) °C Full accuracy only between (-30 to 75) °C
Ambient Humidity	Operating/Storage (10 to 90) %RH non-condensing
Protection requirement	>= IP65 recommended
USB configuration ambient	(10 to 30) °C

MECHANICAL	
Function	Description
Dimensions	43 mm diameter; 21 mm height
Fixing centres	2 x 5 mm holes on 33 mm centres
Centre hole	4.5 mm hole for wiring aid
Connections	Screw terminals 2.5 mm wire maximum
Weight	31 g (encapsulated)

APPROVALS	
EMC	BS EN 61326: Note - Sensor input wires to be less than 3 m to comply
Ingress protection	BS EN 60529
RoHS	Directive 2011/65/EU Incorporating Amendment Directive EU2015/863 and UK designated standard.
ATEX / UKEX TTR200X	Ex ia IIC T4 Ga
	Ex ia IIIC T135 Da
IECEX TTR200X	Ex ia T4 Ga
	Ex ia IIIC T135 Da
EAC	Please refer to www.status.co.uk
DNV	Please refer to www.status.co.uk



TTR200 / TTR200X RTD TEMPERATURE TRANSMITTER

ORDER CODE

STANDARD	TTR200
ATEX / UKEX	TTR200X

MECHANICAL

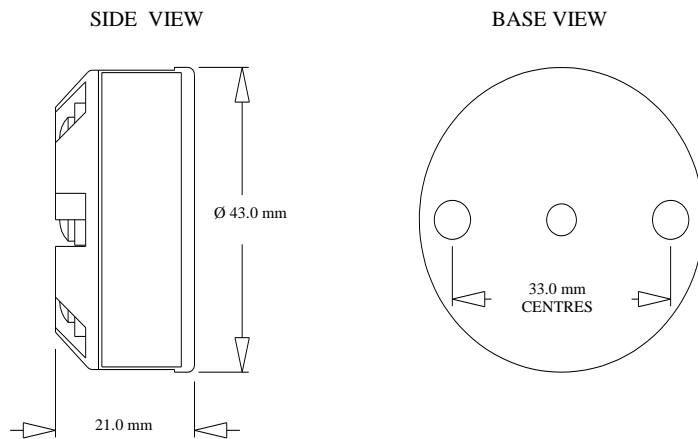

Fixing holes 2 x $\text{Ø}5.5 \text{ mm}$, Centre hole $\text{Ø}4.5 \text{ mm}$



ACCESSORIES	
USB configuration software	USBSpeedLink free of charge from www.status.co.uk
Configuration device	USB-CONFIG-MKII
Configuration device ATEX / UKEX	USBTTX
Head enclosure options	Refer to www.status.co.uk
Probe options	Refer to www.status.co.uk

To maintain full accuracy annual calibration is required contact support@status.co.uk for details
The data in this document is subject to change. Status Instruments assumes no responsibility for errors

D2537-01-08 CN5841 TTR200/ TTR200X Datasheet, Page 4 of 4



ISI sa-nv Instrumentation for Science and Industry (INTERCONTINENTAL SERVICES INC)

Rue du Doyenné 3 Dekenijstraat 1180 Brussels – Belgium - Tel 00 32 2 343 30 81 Email : sales@isi-be.eu web : www.isi-maroc.eu