

TTC200 / TTC200X TC TEMPERATURE TRANSMITTER

- **MULTI TYPE THERMOCOUPLE, mV, INPUTS**
- **ATEX, UKEX AND IECEx APPROVED VERSION**
- **SENSOR OFFSET or OUTPUT ALIGNMENT**
- **ADJUSTABLE INPUT FILTER**
- **PROGRAMABLE BURNOUT**

➤ INTRODUCTION

The TTC200 “smart” in head temperature transmitter accepts thermocouple temperature sensors and converts the sensor output over a configured range to a standard industrial (4 to 20) mA transmission signal. Two versions are available; standard and ATEX / UKEX / IECEx approved for hazardous areas.

PC configuration allows the user to select TC type, Range, Filter, units, linearization and Burnout direction, without requiring calibration equipment. Additionally, the user may read live process data when connected to the PC, this allows for sensor offset and output alignment calibration, where the user can enter values to match the actual process and therefore reducing system errors.

If required the desired range can be specified at the time of order, removing the need for user configuration. If the range is not specified, then the transmitter will be shipped with the default range of (0 to 1000) °C type K, high burnout.

➤ FEATURE HIGHLIGHTS

SENSOR REFERENCING (Temperature mode)

The TTC200 sensor referencing via the Windows based USBSpeedlink software allows for close matching to a known reference sensor eliminating possible sensor errors.

CUSTOM LINEARISATION

As standard the TTC200 has all common thermocouple sensors available from its software library. Additionally, the TTC200 can be programmed with up to 22-point custom linearization for mV inputs between ± 200 mV.

SENSOR BURN OUT DETECTION (Temperature mode)

If a sensor wire is broken or becomes disconnected the TTC200 output will automatically go to its user defined level (upscale or downscale) or a pre-set value.

STABILITY

The TTC200 in head transmitter incorporates the latest digital technology to ensure accurate, low drift performance.

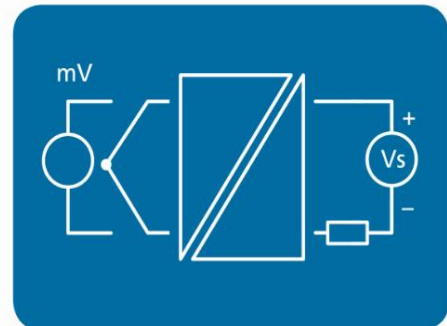

TTC200 / TTC200X TC TEMPERATURE TRANSMITTER

ELECTRICAL INPUT		SPECIFICATIONS @20 °C
Type	Range	Accuracy/ Stability
mV		
(-200 to 200) mV full scale	(-100 to 200) mV (-200 to -100) mV	± 0.02 % of full scale ± 0.05 % of full scale

SENSOR INPUT Thermocouple		SPECIFICATIONS @20 °C
Type	Range	Accuracy/ Stability
K	(-150 to 1370) °C	±0.1 % of full scale ± 0.5 °C (plus sensor error)
J	(-200 to 1200) °C	
E	(-260 to 1000) °C	
N	(-270 to 1300) °C	
L	(-200 to 900) °C	
U	(0 to 600) °C	
B	(0 to 1800) °C	
C, D, W	(0 to 2300) °C	±0.2 % of full scale ± 0.5 °C (plus sensor error)
T	(-270 to 400) °C	
R, S, (0 to 1750) °C full scale	(800 to 1600) °C	± 0.1 % of full scale plus ± 0.5 °C (plus sensor error)
Thermal drift	Offset Span	0.1 °C / °C 0.05 °C / °C
Library contains more standard TC types		

COLD JUNCTION		SPECIFICATIONS @20 °C
Type	Range °C	Accuracy/ Stability
Thermistor bead	(-40 to 85) °C	± 0.2 °C
Thermal drift	Zero at 20 °C	± 0.05 °C / °C

OUTPUT		SPECIFICATIONS @20 °C
Type/ Function	Range/ Description	Accuracy/ Stability/ Notes
Two wire current	(4 to 20) mA	(mA output /2000) or 5 uA (Whichever is the greater)
Thermal drift	Zero at 20 °C	2 uA / °C
Maximum output current	20.5 mA	In high burnout condition
Minimum output current	< 3.9 mA	In low burnout condition
Loop voltage effect	0.2 uA / V	
Maximum output load	[(V supply - 10)/20] KΩ	700 Ω @ 24 V DC
Loop supply	(10 to 30) V DC	SELV
Power	< 1 W full power	

USB USER INTERFACE		
Type/ Function	Range/ Description	Notes
Configuration hardware	For TTC200	USB-CONFIG-MKII
	For TTC200X	USB-CONFIG-MKII USB-TTX-CONFIG
Configuration software	USBSpeedLink	Download www.status.co.uk

TTC200 / TTC200X TC TEMPERATURE TRANSMITTER

Type/ Function	Range/ Description	Notes
Temperature mode configuration	Sensor type	Thermocouple list
	Temperature range for (4 to 20) mA retransmission	°C or °F
	Sensor offset	°C or °F
	Burnout current	Upscale, downscale or user set
Process mode configuration	Input type	mV
	Process range for (4 to 20) mA retransmission	User engineering units, 4 characters
	User linearisation	(2 to 22) segments
Tag number		20 characters
Filter	(0 to 100) s time constant	Adjustable
Read live data	Temperature / process output	°C or °F or user units for process mV
Save/ open configuration	From file	

GENERAL	
Function	Description
Update time	160 ms
Response time	0.5 s
Start-up time	5 s
Warm up time	120 s to full accuracy
Isolation	Input to output 500 Vdc: Working voltage 50 Vdc
Default configuration	Thermocouple type K (0 to 1000) °C, upscale burnout

ENVIRONMENTAL	
Function	Description
Ambient temperature	Operating/Storage (-40 to 85) °C Full accuracy only between (-30 to 75)°C
Ambient Humidity	Operating/Storage (10 to 90) %RH non-condensing
Protection requirement	>= IP65 recommended
USB configuration ambient	(10 to 30) °C

MECHANICAL	
Function	Description
Dimensions	43 mm diameter; 21 mm height
Fixing centres	2 x 5 mm holes on 33 mm centres
Centre hole	4.5 mm hole for wiring aid
Connections	Screw terminals 2.5 mm wire maximum
Weight	31 g (encapsulated)



TTC200 / TTC200X TC TEMPERATURE TRANSMITTER

APPROVALS	
EMC	BS EN 61326: Note - Sensor input wires to be less than 3 m to comply
Ingress protection	BS EN 60529
RoHS	Directive 2011/65/EU Incorporating Amendment Directive EU2015/863 and UK designated standard.
ATEX / UKEX TTC200X	Ex ia IIC T4 Ga Ex ia IIIC T135 Da
IECEX TTC200X	Ex ia T4 Ga Ex ia IIIC T135 Da
EAC	Please refer to www.status.co.uk
DNV	Please refer to www.status.co.uk

ORDER CODE	
STANDARD	TTC200
ATEX / UKEX	TTC200X

MECHANICAL

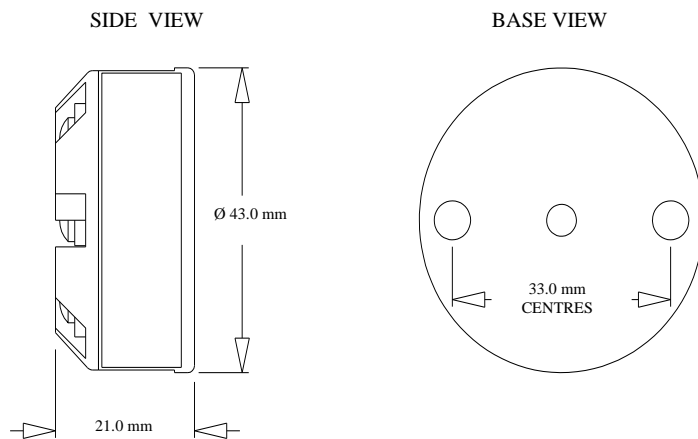

Fixing holes 2 x Ø5.5 mm, Centre hole Ø4.5 mm

ACCESSORIES	
USB configuration software	USBSpeedLink free of charge from www.status.co.uk
Configuration device	USB-CONFIG-MKII
Configuration device ATEX / UKEX	USBTTX
Head enclosure options	Refer to www.status.co.uk
Probe options	Refer to www.status.co.uk

To maintain full accuracy annual calibration is required contact support@status.co.uk for details
The data in this document is subject to change. Status Instruments assumes no responsibility for errors

D2536-01-10 CN5841 TTC200 / TTC200X Data sheet, Page 4 of 4



ISI sa-nv Instrumentation for Science and Industry

(INTERCONTINENTAL SERVICES INC)

Rue du Doyenné 3 Dekenijstraat 1180 Brussels – Belgium - Tel 00 32 2 343 30 81 Email : sales@isi-be.eu web : www.isi-maroc.eu